

JLG 520 AJ

Specifications

Standard Features

- 1.24 m (4ft 1in) Articulating Jib
- 0.76 m x 1.83 m (30in x 72in) Platform Side Entry
- 180 Degree Hydraulic Platform Rotator
- Platform Console Machine Status Light Panel*
- AC cable to Platform
- 5 Degree Tilt Alarm/Indicator Light
- Swing Out Engine Module
- Dura Tough gull-wing turntable hoods
- 12V-DC Auxiliary Power
- Hourmeter
- Interactive Display at Ground Controls
- Control ADE® Advanced Design Electronics System
- Lifting/Tie Down Lugs
- Horn
- Four-Wheel Hydrostatic Drive
- Oscillating Axle
- Cast Aluminum Control Box
- Motion Alarm
- Platform Tool Tray
- Side entry with drop bar mid rail
- Multiple function operation
- Full proportional drive joystick control with integral thumb steer switch
- Full proportional main boom and swing joystick control
- Multiple speed control for telescope and platform rotate
- Selectable creep speed on drive / lift and swing functions
- Load sensing system
- Engine distress warning/shut down system
- Ground control selector switch with key lock
- Dual rated platform capacity up to 450 kg
- JLG Skyguard active system

* Provides indicator lights at platform control console for system distress, low fuel, 5 degree tilt light, and foot switch status.

Performance

- Working Height 18 m
- Working Outreach 10.65 m
- Up and Over Height 7.3 m
- Swing 355 Degrees Non-Continuous
- Platform Capacity 250 kg
- Platform Size 0.76 x 1.83 m
- Platform Rotator 180 Degrees Hydraulic
- Dimensions:
 - A. Platform Size 0.76 m x 1.83 m
 - B. Overall Width 2.35 m
 - C. Tailswing (working condition) Zero
 - D. Stowed Height 2.27 m
 - E. Stowed Length 7.77 m
 - F. Wheelbase 2.36 m
 - G. Ground Clearance 0.42 m
- Jib 1.24 m
- Range of Articulation 144 Degrees (+76, -69)
- Weight ^{1/2} 7,985 kg
- Max Ground Bearing Pressure ² 6.6 kg/cm²
- Drive Speed 6.8 km/hr
- Gradeability 45%
- Axle Oscillation 10 cm
- Turning Radius
 - Inside 2.06 m
 - Outside 4.78 m

¹ Certain options or country standards may increase weight and/or dimensions

² With Standard tires

Dimensions

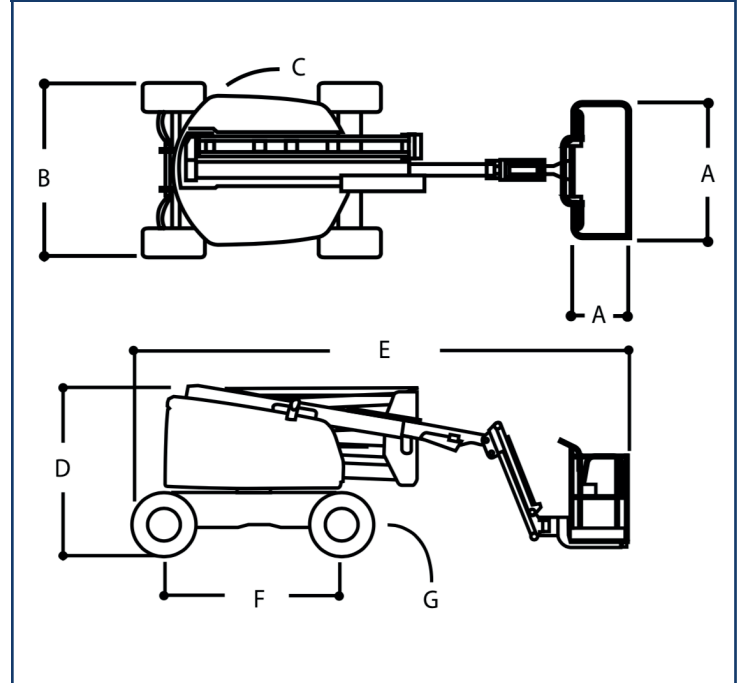

Working ranges

