

JLG 1500 AJP

Specifications

Standard Features

- 0.91 x 2.44 m Platform
- Articulating Jib
- Dual Rated Capacities (270 kg / 450 kg)
- Drive-Out Extendable Axles
- 180° Hydraulic Platform Rotator
- AC Receptacle in Platform
- Tilt Light and Alarm
- Swing-Out Engine Tray
- 12V-DC Auxiliary Power
- Hourmeter
- Control ADE®
- Advanced Design Electronics System
- Hydrostatic drive transmission
- Proportional Controls
- Gull-Wing Steel Hoods
- Platform Console Machine Status Light Panel¹
- Lifting/Tie Down Lugs
- Engine Distress Warning/Shutdown-Selectable via JLG Analyzer
- All Motion Alarm
- LCD Panel at Operator's Platform Control Console
- Quik Stik®
- Tool Tray
- JLG Skyguard active system
- Low fuel engine cut-out
- Cast Aluminum Control Box
- Horn
- Side entry with drop bar mid rail
- Interactive Display at Ground Controls

Performance

- Working Height 48.15 m
- Working Outreach 23.55 m
- Up and Over Height 18.40 m
- Swing 360° Continuous
- Platform Capacity-Restricted 450 kg
- Platform Capacity-Unrestricted 270 kg
- Platform Rotator 180° Hydraulic
- Jib Length 2.44 m
- Jib Range of Articulation 130° (+75, -55)
- Jib Horizontal Rotation 125° (55 right, 70 left)
 - A. Platform Size 0.91 m x 2.44 m
 - B¹. Overall Width (Axles Retracted) 2.50 m
 - B². Overall Width (Axles Extended) 5.00 m
 - C. Tailswing (working condition) 0.70 m
 - D. Stowed Height 3.10 m
 - E¹. Stowed Length 15.10 m
 - E². Stowed Length (transport position) 12.10 m
 - F. Wheelbase (axles extended) 4.60 m
 - G. Ground Clearance 0.30 m
- Weight¹ 26,027 kg
- Max. Ground Bearing Pressure 7.03 kg/cm² TBD
- Drive Speed 4.5 km/h
- Gradeability 40%
- Turning Radius (Inside)
- Axles Retracted 7.10 m
- Axles Extended 2.30 m
- Turning Radius (Outside)
- Axles Retracted 9.50 m
- Axles Extended 6.60 m

¹ Certain options or country standards may increase weight and/or dimensions.

Dimensions

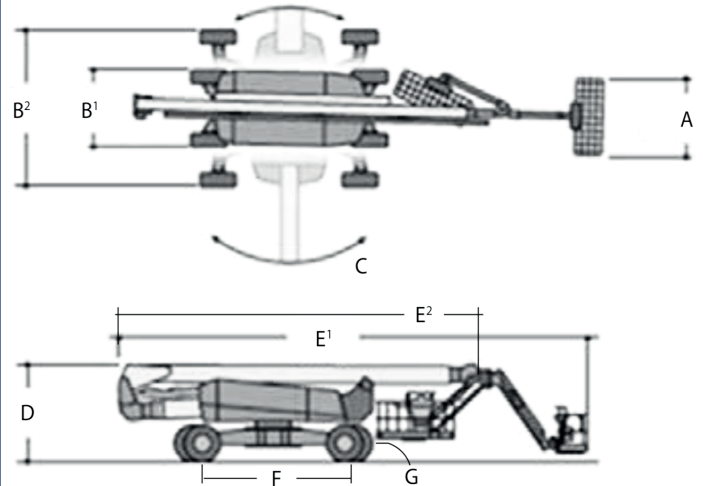

Working ranges

