

# JLG ES1932

## Specifications

### Performance

Platform Height-Elevated (Indoor / Outdoor)		
ES1932i	19 ft / NA	5.8 m / NA
ES1932	19 ft / 19 ft	5.8 m / 5.8 m
Platform Capacity (Indoor / Outdoor)		
ES1932i	507 lb / NA	230 kg / NA
ES1932	507 lb / 507 lb	230 kg / 230 kg
Capacity on Platform Extension		
ES1932i / ES1932	265 lb	120 kg
Number of Occupants (Indoor / Outdoor)		
ES1932i	1 / 0	
ES1932	2 / 1	
Lift/Lower Time		
ES1932i / ES1932	22/24 seconds	
Maximum Drive Height (Indoor)		
Fully Elevated		
Maximum Drive Height (Outdoor)		
ES1932i	N/A	
ES1932	Fully Elevated	
Weight*		
ES1932i	2,675 lb	1,213 kg
ES1932	3,353 lb	1,521 kg
Ground Bearing Pressure		
ES1932i	103 psi	7.2 kg/cm <sup>2</sup>
ES1932	114 psi	8.0 kg/cm <sup>2</sup>
Drive Speed-Elevated		
0.5 mph		
Drive Speed-Lowered		
ES1932i/ES1932	3.0 mph	4.8 km/h
Gradeability		
25%		
Tilt Rating - Side To Side (Indoor / Outdoor)		
ES1932i	2.75 degrees / NA	
ES1932	1.75 degrees / 1.50 degrees	
Tilt Rating - Fore and Aft		
ES1932i	2.75 degrees	
ESR1932	3.75 degrees	
Turning Radius (Inside)		
0		
Turning Radius (Outside)		
ES1932i/ES1932	66 in.	1.7 m

\* Certain options or country standards will increase weight.

### Standard Specifications

#### Power Source

Batteries	
ES1932i/ES1932	4 x 6V 220 amp-hr
Charger	
	27 amp
Drive	
ES1932i/ES1932	24V DC

#### Hydraulic Reservoir

- Capacity (at Full mark)  
ES1932i/ES1932 4.5 gal. 17 L
- Pump  
Fixed Displacement Gear

#### Tires

- Tire Size/Type (Non-Marking)  
ES1932i/ES1932 12.7 x 4 in. 323 x 102 mm

#### Brakes

- Multi-Disc Friction

## Dimensions

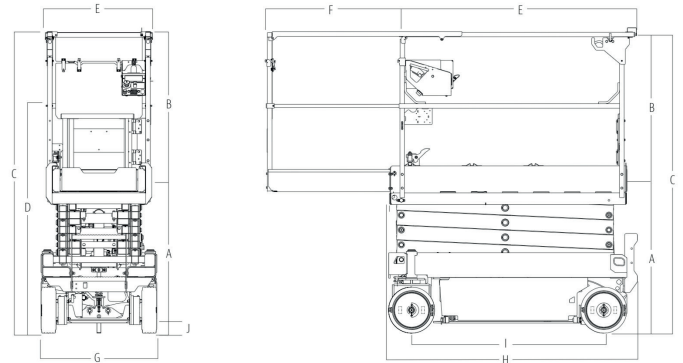

A. Platform Height - Lowered ES1932i / ES1932	38.6 in.	10 m	F. Platform Extension ES1932i / ES1932	36.0 in.	91.0 cm
B. Platform Railing Height ES1932i / ES1932	43.3 in.	110 m	G. Overall Width ES1932i / ES1932	32.0 in.	81.0 cm
C. Overall Height (Rails Raised) ES1932i / ES1932	82.8 in.	21 m	H. Overall Length ES1932i / ES1932	68.7 in.	17 m
D. Overall Height (Rails Lowered) ES1932i / ES1932	78.2 in.	199 m	I. Wheelbase ES1932i / ES1932	53.0 in.	13 m
E. Platform Size ES1932i / ES1932	62.7 in x 25.4 in.	1.59 m x .64 m	J. Ground Clearance (Pothole Protection Not Deployed) ES1932i / ES1932	2.8 in.	70 cm

## Standard features

- QuikFold Rails
- USB Charger & Phone Holder
- CAN-Enabled Charger
- Load Sensing System
- Self-Closing Gate
- Proportional Controls
- Electric Drive
- Battery Condition Indicator
- AC Receptacle in Platform
- All Motion Alarm
- 27 amp Multi-Function Universal Charger
- Horn
- Hourmeter
- Tilt Alarm and Light
- Lanyard Attach Points
- Movable, Removable Platform Control
- Nickel Plated Pins
- Lubrication Free Scissor Arm Bushings
- Scissor Maintenance Prop
- Active Pothole Protection System
- Lifting and Tie Down Points
- Fork Lift Pockets
- Manual Descent Cable
- Foot-Actuated Deck Extension
- Steel Swing-Out Doors
- Variable Tilt Visual Zone Indicator
- Diamond Tread Steel Deck
- Greaseless Kingpin Joints
- Analyzer Port for Diagnostics
- Dynamic Braking
- Removable Ladder
- ANSI A92.20 Compliant